

DEPARTMENT OF COMPUTER AND ELECTRICAL ENGINEERING

EMERGENCY RESPONSE BUTTON

AFUA PREMOH

June 8, 2011

SUBMITTED IN PARTIAL FULFILLMENT OF  
THE DEGREE  
IN BACHELOR OF COMPUTER ENGINEERING TECHNOLOGY

STUDENT SIGNATURE \_\_\_\_\_

ADVISOR SIGNATURE \_\_\_\_\_

Advisor: Elvin Stepp

Afua Premoh  
2630 Euclid Ave. Fl.1  
Cincinnati, Oh 45219

June 7, 2011

Elvin Stepp  
College of Applied Science  
2220 Victory Parkway  
Cincinnati, OH 45206-2839

Dear Professor Stepp:

Attached is my final report for my senior design project, "Emergency Response Button," Which was requested by Professor Stepp, with a deadline of June 8, 2011.

This final report outlines my senior design project titled "Emergency Response Button." This project was first suggested by Professor Stepp. I chose this project because I thought it was a great idea and I could relate to the need for such a project because I have elderly and disabled family members that can use such a device. There is a great amount of need for devices such as Life Alert and Life Line. My initial project was designed to expand upon the original invention of the emergency response button and modify it. The goal of the modification was to improve the emergency button, which would make the device more affordable. The modification could also expand the use for the emergency button. The project that I chose is not the same as Life Alert or Life Line because it has a different design and purpose. While completing this project I ran into many road blocks which will be discussed in the "Problems Encountered Section." My proposed project was to complete an "Emergency Response Button." I was unable to successfully complete the project I proposed to design. I accomplished the first portion of the project, which is a transmitter and receiver remote control project. This report is broken up into two main sections, an introduction and a discussion. The introduction will discuss the problems with existing devices and explain the solution to those problems, my credibility, project goals, and the project's methodology. The discussion section will discuss in detail, the design objectives, technical approach, budgets, timelines, and problems that were encountered and future recommendations.

I owe thanks to Professor Stepp and David Tajhian who helped provide guidance and technical advice throughout the process of completing this project.

Thank you for your time and consideration. If you have any questions, please feel free to contact me at (513)703-5408 or [premohag@ucmail.uc.edu](mailto:premohag@ucmail.uc.edu).

Sincerely,

Afua Premoh

# DEDICATION PAGE

First, I would like to dedicate this project to my family. My parents have supported me from day one. Without the support of my parents, I would not have made it this far. I also want to dedicate this project to my two beautiful children, they motivate me and they are the reason that I strive so hard. Next, I want to give credit to a few people who helped me throughout the year. I want to give thanks to my advisor, Professor Elvin Stepp, for suggesting my senior design topic. He also went beyond of what was required of him to help me complete this project. I also want to thank him for his patience and assistance. Next, I want to thank Professor Wilson and Stoll for their advice and guidance which helped me complete my proposal, poster, presentations, and final report.

# TABLE OF CONTENTS

<b>Abstract.....</b>	<b>1</b>
<b>Introduction.....</b>	<b>2</b>
Problem/Need.....	3
Solution.....	3
Credibility.....	3
Project Goals & Methodology.....	4
<b>Discussion.....</b>	<b>4</b>
Project Concept.....	4
Design Objectives.....	4
Methodology/Technical Approach.....	5-13
Initial Budget.....	14
Final Budget .....	15
Remote Control Budget.....	16
Initial Timeline.....	17
Final Timeline.....	17
Problems Encountered .....	19
Future Recommendations.....	19
<b>Conclusion.....</b>	<b>19</b>
<b>Reference.....</b>	<b>20</b>
<b>Appendices.....</b>	<b>21</b>
Appendix A – 4-bit & 8-bit Remote Control Schematics.....	21
Appendix B – 8051 dev board schematic.....	22
Appendix C – 8-bit Remote Control Encoder/Decoder IC’s documentation...	23-28

**LIST OF ILLUSTRATIONS**

Figure 1: Push button.....5

Figure 2: Transmitter.....5

Figure 3: Encoder schematic.....6

Figure 4: 20 pin DIP Encoder.....6

Figure 5: Receiver schematic.....6

Figure 6: Decoder schematic.....7

Figure 7: LED light.....7

Figure 8: TCM5589 schematic.....8

Figure 9: Dev Board.....10

Figure 10: Complete 8051 Dev Board.....10

Figure 11: TCA3388 schematic.....11

Figure 12: RJ-11.....11

Figure 13: Initial Timeline.....17

Figure 14: Final Timeline.....17

Table 1: Low frequency table.....8

Table 2: High frequency table.....8

Table 3: Dual tone number representation.....8

Table 4: Initial Budget.....14

Table 5: Final Budget.....15

Table 6: Accomplished project budget.....16

# ABSTRACT

Life Line and Life Alert were designed for the sole purpose of helping the elderly or disable receive quick response from medical personnel during an emergency. I thought this topic was a great idea because I could relate to the need for such a project. I have elderly family members that could benefit from such a device. My goal was to take the existing concept of Life Alert of Life Line and improve the design. The purpose of improving Emergency Response Button that exists today was to make the device better for the customers who need it the most. The intended design used wireless devices, a dual-tone multi-frequency integrated circuit, and a microcontroller. Although this design is different from existing Emergency Response Buttons, the concept remains the same. The button can be worn either on around the neck or on the wrist. During an emergency, the button is pressed. Next, a transmitter and encoder, which are wired to the pushbutton, send a signal to the receiving end. On the receiving end, the receiver picks up the signal. A decoder is wired to receiver and 8051 microcontroller. A port from the 8051 is connected to the data line of the decoder. Once the data line goes high, the 8051 signals the DTMF generator to make the phone call. The purpose of the DTMF generator is to generate the tones and the purpose of the microcontroller is to pre-program the emergency phone number. This project modified a device that currently existed, which in result could improve the device for customers.

# INTRODUCTION

Have you ever put yourself in the shoes of your grandmother or grandfather? Living independently as a disabled or elderly person can be very scary, because during an emergency it can sometimes be difficult or impossible to access a telephone to call for help. One of the best qualities of technology is to make life easier. An emergency response button is advancement in technology that serves this purpose.

Two emergency response buttons that are on the market today are “Life Line” and “Life Alert.” Those two products market their services to elderly individuals living independently. There are issues with these devices that can be improved upon. During an emergency, 911 operators are not called directly; the first contact person is an answering service that redirects the call to the 911 call operators. There are three problems with those existing services. The purpose of this senior design project is to solve those three problems. This project improves the emergency response button by decreasing cost and providing assistance during situations other than those that are not medical related. There are situations that can arise where a 911 call may not be needed; for example, during a power outage. There are many of 911 calls made each year that unnecessary. In some situations the family or neighbor can provide assistance, therefore allowing 911 to serve more serious calls.

The purpose of this final report is to discuss, in detail, the “Emergency Response Button” project. Unlike other projects, this project is an emergency tool that can be save someone’s life. This device can be beneficial to any individuals, primarily the elderly or any person with a disability. An emergency response button can be very useful to those people because they encounter more accidents and require more assistance than a person that is not disabled or elderly. This device differs from existing emergency response button that are available today, because it is less expensive, more flexible, and just as effective.

The following report will discuss in depth, the problems with existing devices, the solutions to those problems, the methodology, the hardware used to build the project, how this problem was implemented, the problems that were encountered while building the project, and possible future recommendations for improvements.

## ***PROBLEM/NEED***

This section will discuss the problems that exist with emergency response buttons currently on the market. This project solves two problems that exist with existing emergency response buttons. The first problem that is addressed is the use of a third-party answering service. The use of a third-party answering service caused similar devices to be more expensive. The emergency response button minus a third-party answering service will cause the device to be less expensive.

The second problem that was addressed is linked to the first problem. Since customers are forced to use third-party answering services, they are not given a choice to call an alternative phone number. The third-party answering service redirects the call to 911 if there is an emergency. Sometimes the emergency that occurred may not require the assistance of 911. It may be an emergency that a neighbor or family member may be able to solve. If a neighbor or family can assist with a non-medical emergency, it will relieve 911 operators, and allow them to attend more important calls.

## ***SOLUTION***

This section will discuss the solutions to the problems that exist with emergency response buttons currently on the market. There are two problems previously discussed in the prior section. The first problem was that existing companies that offer the emergency response button require the customers to subscribe to a third-party answering service. There is a monthly fee for this answering service. This project planned to solve that problem. That problem is solved by eliminating the third-party service. When the “ER” button is pressed, the emergency contact is contacted directly.

The solution to the second problem is providing the choice to choose the emergency contact. The second problem previously discussed was 911 being the primary contact person during the emergency. Since all situations do not equal in severity, there should be alternative emergency contacts available to customers during emergencies.

## ***CREDIBILITY***

Currently, I am a senior at the University of Cincinnati’s College of Engineering and Applied Science, majoring in the Computer Engineering Technology. I was able to attempt to build the “Emergency Response Button because of prior classes where I have learned how to wire electronic circuits, and how to use equipment such as oscilloscopes and voltmeters used for testing. I have taken an Embedded Systems course where I was taught how to build the 8051 microcontroller development board circuit that was used in the project. The Embedded Systems course introduced me to the 8051 microcontroller and also taught me how to program the microcontroller using assembly language. The combination of classes taken over the years prepared me to attempt this project.



## ***PROJECT GOALS/BRIEF METHODOLOGY***

The project consisted of three main project goals. The first project goal was to design an emergency push button that was affordable and low in cost. The second project goal was to use a push button worn in a manner that makes it easily accessible to the user. The third project goal was to dial out using a DTMF generator. The DTMF generator was chosen because it is a low cost option to send out tones over the phone line. The fourth goal used an 8051 microcontroller to program the preset phone number. There was more than one microcontroller that could be used for this project, but the 8051 microcontroller was used because I am familiar with that particular microcontroller I was taught the assembly language used to program the 8051 while taking the course embedded systems. Flexible In Circuit Programming (FLIP) was used to program the AT89C51RB2.

## **DISCUSSION**

### ***PROJECT CONCEPT***

The emergency response button concept is a form of technology that has been on the market for many years. An “ER” button uses a push button to receive help. This device is mainly marketed to the elderly and disabled people because they tend to need the most assistance while living independently. Two emergency response buttons that currently exists on the market today are Life Line and Life Alert. The intended goal of this project took an existing concept of an emergency response button and improved upon it.

### ***INTENDED DESIGN OBJECTIVES***

There must be design objectives with any project that is in the process of being developed. In no specific order this project had two design objectives.

- The first design objective was to create an emergency response button that was less costly than emergency response buttons that existed. Current devices are costly because of the use of third party answering service to seek help for the customer.
- The second design objective was to improve upon the idea of “ER” button by programming a telephone number of the customer’s choice using the 8051 microcontroller.

## METHODOLOGY /TEHCNICAL APPROACH

Initially, my goal was to design an emergency response button that included a remote control circuit, DTMF generator, 8051 microcontroller dev board, and a telephone line interface. I was unable to complete my intended design objectives. I actually completed a transmitter and receiver push button circuit. This transmitter and Receiver push button design is the first portion of my overall proposed senior design project.

This section will explain the parts that I used to complete my transmitter and receiver project.

### PUSH BUTTON

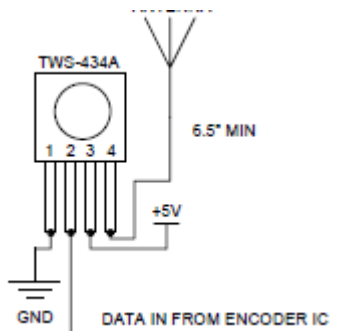

**Figure 1: momentary push button**

The push button shown in figure 1 is a momentary push button switch. This button was used because it is small in size and can be easily worn attached to a necklace or bracelet.

### TRANSMITTER

[TWS-434A](#) Low-Cost 434MHz RF Transmitter Module



**Figure 2: Transmitter**

The transmitter used is a low-cost, low range module. The transmitter shown below operates at 434 MHz range. This transmitter in figure is wired to an encoder IC chip.

## ENCODER

tem: CIP-8E Encoder IC. 8-Bit Address/Data

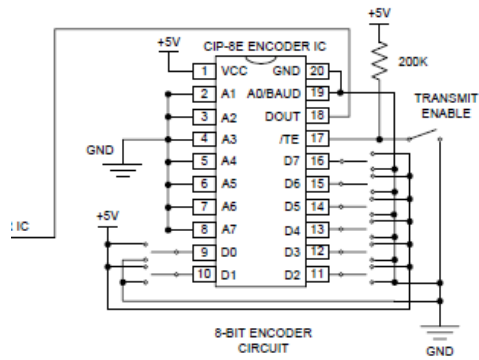

Figure 3: Encoder

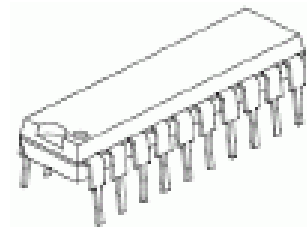

Figure 4: 20 pin DIP Encoder

## RECEIVER

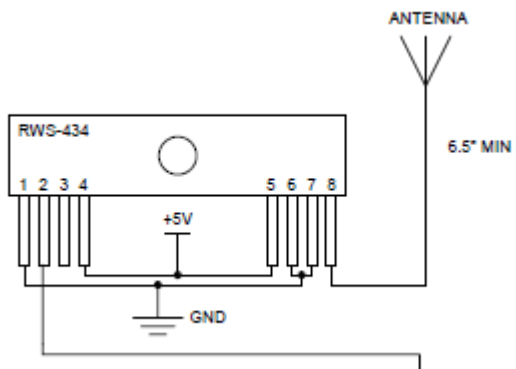

Figure 5: Receiver

[RWS-434](#) Low Cost 434MHz RF Receiver Module



This senior design project intended to include the below hardware.

### DTMF GNERATOR INTEGRATED CIRCUIT CHIP

DTMF is short for dual tone multi-frequency. The IC in Figure 4 outputs frequencies. The frequencies that are outputted are shown in Table 1 and Table 2.

One low and one high frequency paired together generate a tone.

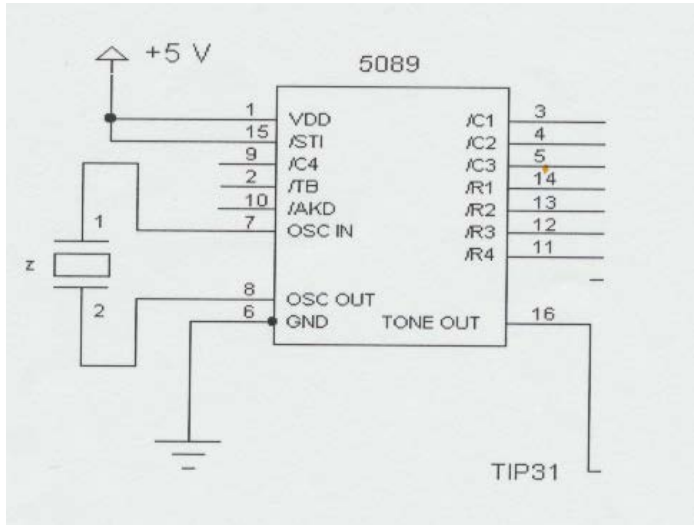

Figure 8:TCM5589 Schematic

### DUAL TONE MULTI-FREQUENCY

Row/Column Frequencies

ROW #	Low -FREQUENCY (HZ)
R1: ROW 0	697
R2: ROW 1	770
R3: ROW 2	852
R4: ROW 3	941

Table 1: Low Frequency

COL #	High -Frequency (HZ)
C1: COL 0	1209
C2: COL 1	1336
C3: COL 2	1477
C4: COL 3	1633

**Table 2: High Frequency**

(1) 1209 + 697	(2) 1336 + 697	(3) 1477 + 697
(4)1209 + 770	(5) 1336 + 770	(6) 1477 + 770
(7)1209 + 852	(8) 1336 + 852	(9) 1477 + 852
(*)1209 + 941	(0) 1336 + 941	(#) 1477 + 941

**Table 3: Dual tone number representation**

### Atmel Flash AT89C51RB2

This particular microcontroller has an on board data memory. Once the microcontroller is flashed, the onboard data memory allows the microcontroller to operate without being connected to the computer. This feature is necessary with a project that must be portable.

### 8051 MICROCONTROLLER

Below are figures of two development pc boards that contain the 8051 microcontroller. Figure 5 displays a basic development pc board. The second figure below shows a completed 8051 development board. For the complete dev board schematic refer to Appendix B.

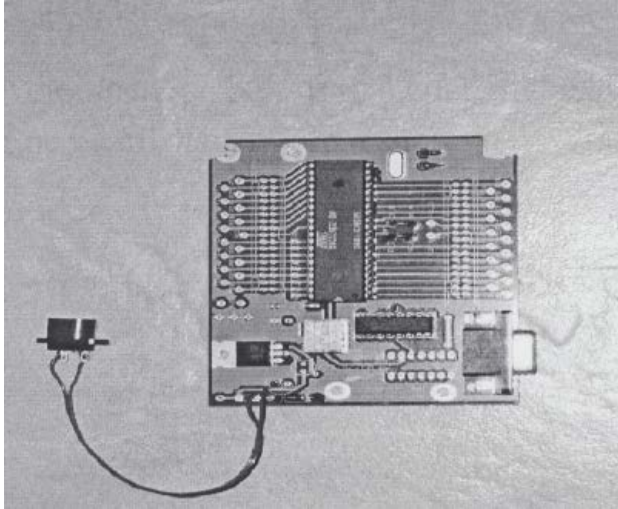

Figure 9: Dev board

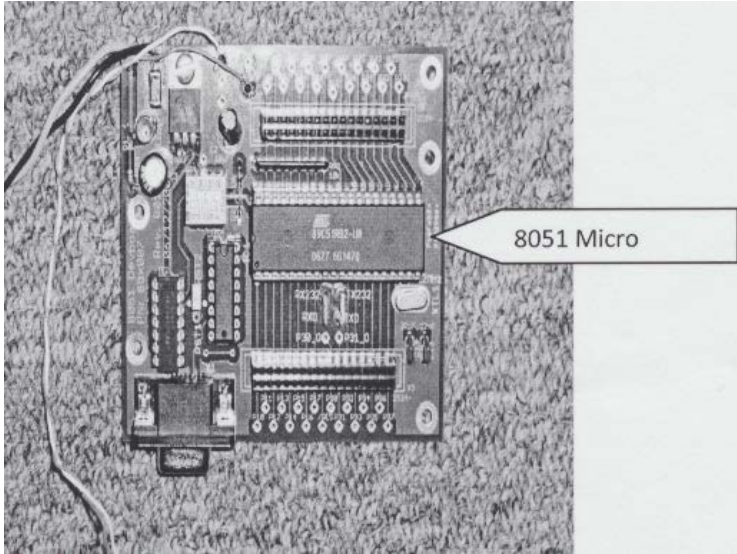

Figure 10: Complete Dev board

## FLIP SOFTWARE

FLIP software is used to program the Atmel Flash AT89C51RB2 microcontroller. Below are steps that should be completed prior to using the software.

1. First, the assembly language text file must have an .asm extension. The file should be named file.asm.
2. Second, save the file in a directory that contains the A51.exe assembler. The assembler takes the text file, file.asm, and converts it to machine code for the microcontroller.
3. Third, a file.obj will be generated when the file is assembled successfully.
4. The file.obj in a hex file that is used by the programmer to program the microcontroller.

## TELEPHONE LINE INTERFACE

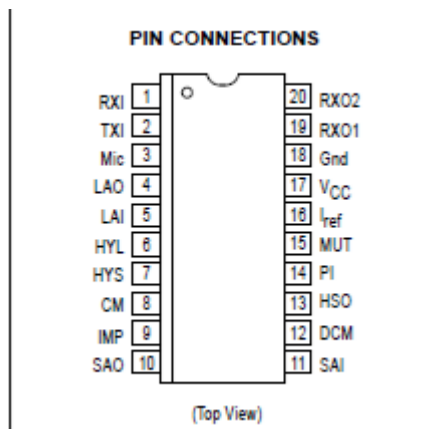

Figure 11: TCA3388 Telephone line Interface

## REGISTERED JACK RJ-11

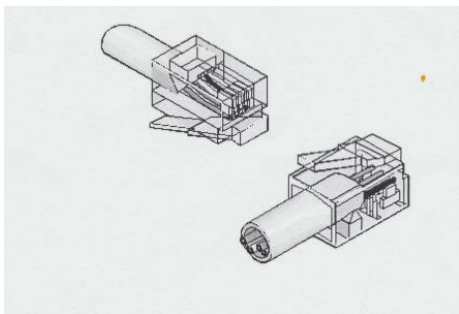

Figure 12: RJ-11



# ACCOMPLISHED

The first portion of my intended project was to complete a remote control circuit. The first portion of the intended project was successfully completed. The following will explain how this push transmitter and receiver circuit operates. A transmitter, encoder, receiver, and decoder were purchased from [www.rentron.com](http://www.rentron.com). For a complete schematic refer to Appendix A.

## **TRANSMITTER/ENCODER**

- First, a transmitter is wired to the encoder using the schematic provided by [www.rentron.com](http://www.rentron.com). These components are wired on bread board.
- Second, a push button is attached to pin 17 on the encoder chip. This is the transmit enable line.
- Third, the antennas are attached to the transmitter. A wire 6.5 inch wire is used for the antenna.
- Fourth, all data lines on the encoder are tied to ground except for 1, which is used to transmit data to the transmitter. D1 is used to transmit data in this particular project.
- Sixth, on the encoder chip, all address lines are tied to a set value. In this particular project, all address lines are tied to ground.

## **RECEIVER/DECODER**

- First, using the schematic giving by [rentron.com](http://rentron.com), the receiver is wired to a decoder on a second bread board.
- All address lines are tied to ground to match the value of the address lines on the encoder.
- All data line is tied to ground except for the data line that is tied high on the encoder.
- A Led is wired to D1 on the Decoder. D1 is the data line that is tied high on the encoder.

## **OPERATION**

The transmitter and receiver push button should operate as follows.

1. Power is applied to the transmitter and receiver.
2. The push button is pressed.
3. On the receiving end, the led that is wired to decoder, lights up.
4. Once this button is let go, the light should go off.
5. If the push button is held, the light is expected to stay on for that duration.
6. The LED light indicates that data was received from receiver from the transmitter.

# BUDGET

Once of the goals for this project was to design a low cost emergency response button. The initial plan was for this project to use seven parts totaling \$38.29. The Microcontroller Dev was purchased by the ECET department. The remote control project which included a transmitter, receiver, encoder, and decoder were purchased online at Rentron electronics. Next, I discovered a telephone line interface IC (TCA3388) that necessary to complete this project. The final budget included the TCA3388; therefore, the final total cost to perform this project was 54.29. The first portion of this project, which was actually accomplished, totals \$28.79. Table 6 is a remote control project that was actually accomplished. The below tables give the part description, vendor, quantity, cost, and total costs.

## *INITIAL BUDGET*

Part Name	Vendor	Quantity	cost
	<i>Undergraduate</i>		
Push Button	Radio Shack	1	\$3.29
TWS-434A Transmitter	Rentron Electronics	1	\$8.50
RWS-434A Receiver	Rentron Electronic	1	\$8.50
CIP 8D 8-bit Decoder	Rentron Electronic	1	\$4.00
CP 8D 8-bit Decoder	Rentron Electronic	1	\$4.00
89C51RB2 Dev board	Provided by College of Applied Science(ECET)	1	\$0
TCM5589N DTMF generator IC	Debco Electronics	1	\$5.00
Registered Jack	Wal-Mart	1	\$5.00
Total	998	7	38.29

Table 4: Initial Budget

## ***FINAL BUDGET***

<b>Part Name</b>	<b>Vendor</b>	<b>Quantity</b>	<b>cost</b>
	<i>Undergraduate</i>		
Push Button	Radio Shack	1	\$3.29
TWS-434A Transmitter	Rentron Electronics	1	\$8.50
RWS-434A Receiver	Rentron Electronic	1	\$8.50
CIP 8D 8-bit Decoder	Rentron Electronic	1	\$4.00
CP 8D 8-bit Decoder	Rentron Electronic	1	\$4.00
89C51RB2 Dev board	Provided by College of Applied Science(ECET)	1	\$0
TCM5589N DTMF generator IC	Debco Electronics	1	\$5.00
TCA3388(Telephone line interface)	Motorola	1	\$16.00
Registered Jack	Wal-Mart	1	\$5.00
<b>Total</b>	<b>998</b>	<b>7</b>	<b>54.29</b>

Table 5: Final Budget

## REMOTE CONTROL BUDGET

College	New students	Graduating students	Change
	<i>Undergraduate</i>		
TWS-434A Transmitter	Rentron Electronics	1	\$8.50
RWS-434A Receiver	Rentron Electronic	1	\$8.50
CIP 8D 8-bit Decoder	Rentron Electronic	1	\$4.00
CP 8D 8-bit Decoder	Rentron Electronic	1	\$4.00
LED	Radio Shack	1	\$1.50
Push Button	Radio Shack	1	\$3.29
<b>Total</b>			<b>\$28.79</b>

Table 6: Accomplished project budget

# TIMELINE

The initial timeline is a schedule that I planned to follow while completing the “Emergency Response Button.” Due to the problems that I experienced while trying to complete this project, the project lasted longer than the initial timeline. The actual timeline accurately explains the duration of the project.

## INITIAL TIMELINE

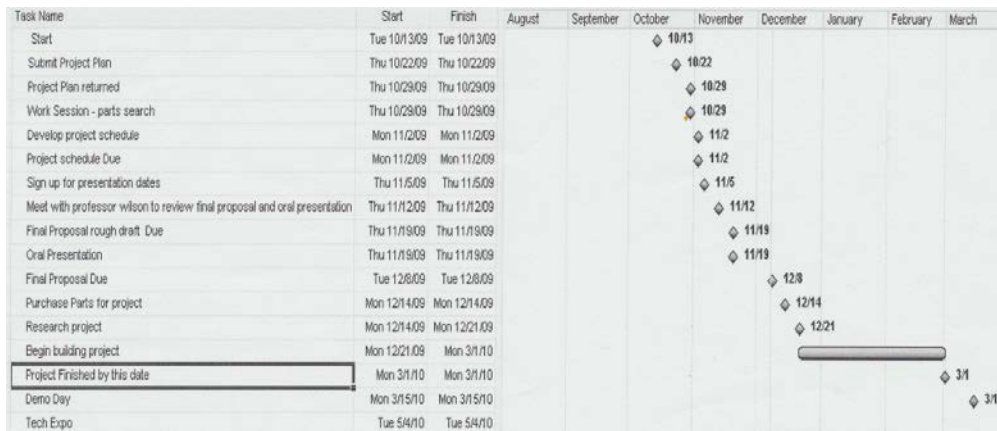

Figure 13: Initial Timeline

## ACTUAL TIMELINE

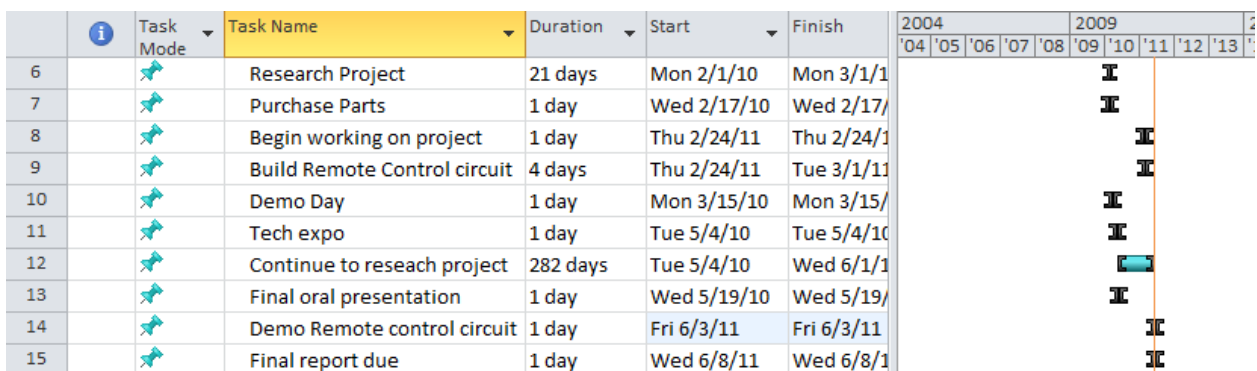
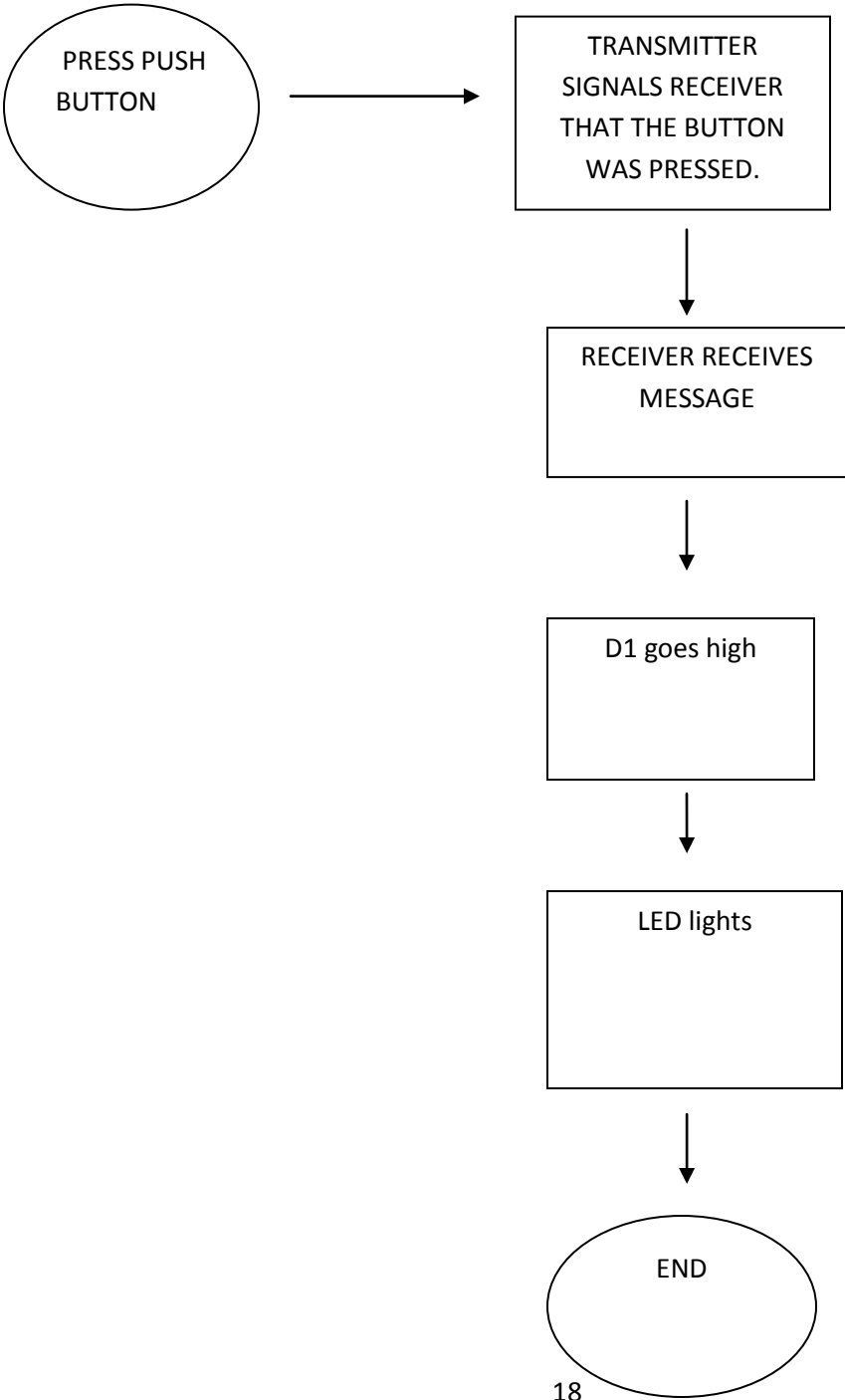

Figure 14: Final Timeline

# FLOW CHART (TRANSMITTER/RECEIVER PUSH BUTTON CIRCUIT)

Below is flow chart of a remote control project. A remote control project is the first portion of the overall “Emergency Response Button” Design. This flow explains the logic behind the remote control project.



## **PROBLEMS ENCOUNTERED**

Initially my goal was to design an “Emergency push button” that built upon the idea of existing Emergency response buttons. My goal was design an emergency response button that is cheaper than existing “ER” buttons to date and one that contacted a wider range of people. I was unable to design such a device. The biggest problem that ran into was interfacing a dtmf generator and microcontroller with the phone line. I was unable to design a circuit that could dial out a pre-programmed phone number directly. The most important design with this project was interfacing with the phone line. This project is unable to function without this capability. Towards the end of senior design, I discovered a telephone line interface IC. I was unable to complete the project. The portion that was completed was the remote control circuit which was necessary for the customer to communicate with a telephone device.

## **FUTURE RECOMMENDATIONS**

A future recommendation for this project can be to design an Emergency Response button that dials a pre-programmed phone number that alerts the person on the receiving during an emergency. An IC chip that can be used to interface with the phone line is a Motorola TCA3388. Refer to Appendix D for schematic information. This IC is a Telephone line interface that performs the basic functions of a telephone set in combination with a microcontroller and a ringer. The TCA3388 allows for DTMF interfacing. Once a pre-recorded phone number can be dialed out, the call being made should have a pre-recorded message for the person on the receiving end. A second recommendation is have a text message that ends alerts to a person the receiving end during an emergency versus a telephone call.

## **CONCLUSION**

In Conclusion, The proposed project was an emergency response button that dials out a pre-programmed phone number during an emergency. The proposed project was partially completed. The first portion of the project was completed. The first portion of the intended project was a transmitter/Receiver push button circuit. For the receiver and transmitter circuit, once the push button is pressed, the led light on the receiving end lights up. The led light indicates whether the data was received by the receiver. While designing a new and improved Emergency Response button, I ran into a road block. I was unable to solve the problem of interfacing a DTMF generator to the phone line. It further explained in the Future Recommendation section how a person can expand upon this idea.



# REFERENCES

## *8-bit module Remote Control Kit*

Rentron Electronics < [http://www.rentron.com/remote\\_control/TWS-4-bit-pack.htm](http://www.rentron.com/remote_control/TWS-4-bit-pack.htm) < 8 June 2011

## *Schematic PDF*

Rentron Electronics < [http://www.rentron.com/Files/CIP8\\_TWS8BIT.pdf](http://www.rentron.com/Files/CIP8_TWS8BIT.pdf) < 8 June 2011

## *8-Bit RF Remote Control Schematics with CIP-8E/CIP-8D encoder/decoder documentation.*

Rentron Electronics < <http://www.rentron.com/Files/CIP-8.pdf> < 8 June 2011

Motorola TCA3388/D < <http://www.telephonetribute.com/pdf/tca3388rev0.pdf> < 8 June 2011

# APPENDIX A

## 4 & 8-Bit RF Remote Control Schematics

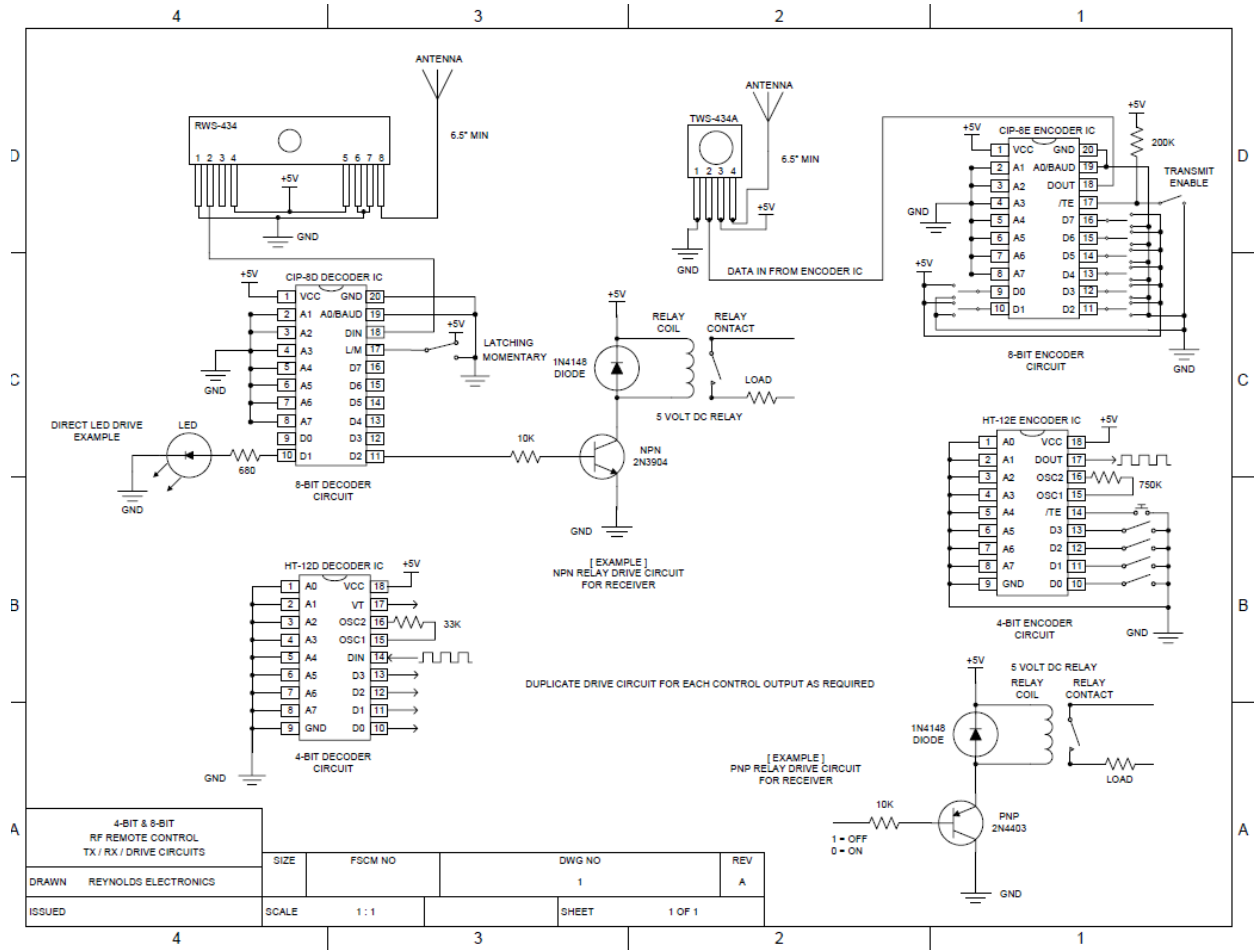



# APPENDIX C

## (DOCUMENTATION)

### CIP-8 8-Bit Remote Control Encoder/Decoder IC's

#### **Description**

The CIP-8 series 8-bit encoder/decoder IC's offer an easy to use, low-cost solution for simple remote control applications in a convenient industry standard 20-pin PDIP package.

#### **Encoder Operation**

On power-up the encoder enters low power sleep mode. When the transmit enable pin is pulled to ground, the encoder will wake up and begin the transmit process.

First, the encoder will record the state of the 8-bit address/data lines, encode for error correction and assemble the packet. It will then sample the A0/BAUD pin to fix the data rate, and then output the address and encoded data packet on DOUT.

The encode/transmit process will continue for as long as the /TE pin is low, and return to low power sleep mode when /TE returns high.

It will update the state of the address and data lines with each packet and finish the current transmission even after the /TE pin is released from ground.

#### **Encoded Data Packet**

Each data packet consists of seven bytes of information to be transmitted.

- The preamble
- The synchronization byte
- The 1<sup>st</sup> address byte
- The 1<sup>st</sup> data byte
- The 2<sup>nd</sup> address byte
- The 2<sup>nd</sup> data byte
- The address/data checksum

A 10mS guard time is inserted between each encoded packet transmission to allow the decoder time to receive, decode, verify, and process each packet. The encoder returns to low power sleep mode for power conservation immediately once /TE returns

to logic 1, and the packet transmission is Complete.

#### **Features**

- Latched or momentary outputs
- No programming necessary
- Very easy to use
- Very low component count
- Low current consumption
- Up to 25mA per decoder output
- Eight bit data (D0 to D7)
- Eight bit binary address (0 to 255)
- Selectable baud rates (2400/4800)
- High noise immunity
- Standard 20-pin PDIP package

#### **Applications**

- Simple remote control
- Wire elimination
- Remote status monitoring
- Remote lighting control

#### **Decoder Operation**

The decoder enters a timed loop waiting for the synchronization byte. An internal 16-bit timer is used to force an exit from the receive loop, and reset the output pins (in momentary mode) every 65.5mS if no valid synch byte is received during this time period.

Once a valid synch byte is received, the timer is disabled, and the remainder of the data packet is received and stored for the verification process.

Immediately after receiving a valid data packet it begins the process of verifying the data, and checking it for errors.

Once data has been verified, the decoded data will be placed on the output pins, and the decoder re-enters the timed loop waiting for the next valid packet.

If the decoder is operating in latch mode, the last valid 8-bit binary data value received will remain on the decoder outputs until a different valid binary data packet is received.

1

### **CIP-8**

#### **8-Bit Remote Control Encoder/Decoder IC's**

##### **Pin Descriptions**

Pins A0 to A7 on the CIP-8 encoder and decoder IC's are used to set a unique address relationship between the encoder and decoder.

This helps prevent accidental activation of decoder outputs, and allows a single encoder the ability to control multiple decoders by

simply changing the encoder address to match the decoder to control.

Ensure the address set on the encoder matches the decoder you wish to control. A single bit difference, and the decoder will not respond.

#### **A0/BAUD Pin**

The A0/BAUD input serves two functions. One is being the least significant bit of the 8-bit encoder/decoder address. Two is being the data rate selection pin. With A0/BAUD connected to ground, the least significant bit of the 8-bit binary address is 0, and the serial data rate is 2400bps.

With this pin at Vcc, the least significant address bit is 1, and the serial data rate is 4800bps. This option allows support for lowend RF modules that require the lower data rates, while providing the faster data rate option for higher end RF modules such as the excellent Linx Technologies® LR series, and others.

#### **Encoder & Decoder Data Pins D0-D7**

On the encoder, pins D0-D7 are the data input pins. The logic value present on these inputs will be transferred to the corresponding D0-D7 data output pins on the decoder when /TE (transmit enable) pin on the encoder is pulled to ground.

#### **Encoder /TE Pin**

/TE is the transmit enable pin. This pin will cause the encoder to sample the address and data pins, and transmit continuously while held at ground. Returning /TE to Vcc through the pull-up resistor as shown in the CIP-8 example schematics will end the transmission, and place the encoder in low power sleep mode.

#### **Decoder Latch/Momentary Modes**

The decoder L/M pin provides a mode select to switch between momentary or latched decoder operating modes.

Logic 1 = Latch Mode

Logic 0 = Momentary Mode

In momentary mode, the decoder outputs that will maintain the 8-bit data value being received for the duration of valid address and data reception.

If any part of the verification process fails, or reception is interrupted for longer than 65.5mS, decoder will timeout, immediately discard the packet, reset the timer, force all decoder data outputs back to ground, and re-enter the timed loop waiting for the next packet.

When receiving a continuous stream of valid data, the timer is disabled, and the decoder will respond rapidly to changing data values, and hold the received binary pattern on the outputs.

**Connect All Pins**

All address, data, and function select pins such as /TE, and L/M pins must be connected to either Vcc or ground as required. Leaving any pins floating (not connected) will cause erratic operation of the encoder, decoder, or both.

Ensure that encoder data inputs D0-D7 are at the required logic levels before the /TE pin is pulled to ground.

When prototyping circuits on a breadboard, it may be desirable to test logic levels on all encoder/decoder pins with a logic probe or meter before operation.

**VCC And Ground**

VCC is the positive power supply. GND is ground.

**Ordering Information**

Part # Description

CIP-8D □□□□□□□□□□□□□□ Bit Decoder IC

CIP-8E □□□□□□□□□□□□□□ Bit Encoder IC

2

**CIP-8**

**8-Bit Remote Control Encoder/Decoder IC's**

3

**Electrical Characteristics**

Parameter Designation Min. Typ. Max. Units Notes

Supply Voltage Vcc 3.0 -- 5.5 VDC

Supply Current IDD

@ 3.0V VCC --- 500 TBD  $\mu$ A 1

@ 5.0V VCC --- 800 TBD  $\mu$ A 1

Sleep Current

@ 3.0V VCC --- 0.1 0.85  $\mu$ A

@ 5.0V VCC --- 0.2 0.95  $\mu$ A

Input Low Voltage VIL GND --- 0.2 VCC V 2

Input High Voltage VIH 0.8 VCC --- VCC V 3

Output Low Voltage VOL --- --- 0.6 V

Output High Voltage VOH VCC - 0.7 --- --- V

**Notes**

1. Current consumption with no active loads

2. For 3V supply, (0.2 x 3.0) = 0.6V max.

3. For 3V supply, (0.8 x 3.0) = 2.4V min.

**Absolute Maximum Ratings**

Ambient temperature under bias.....-40° to +125°C

Storage temperature ..... -65°C to +150°C

Voltage on VDD with respect to Vss ..... -0.3V to +6.5V

Voltage on MCLR with respect to Vss ..... -0.3V to +13.5V

Voltage on all other pins with respect to Vss ..... -0.3V to (VDD + 0.3V)

Total power dissipation ..... 800 mW

Maximum current out of Vss pin ..... 300 mA

Maximum current into VDD pin ..... 250 mA

Input clamp current, IIK (VI < 0 or VI > DD).....± 20 mA

Output clamp current, IOK (Vo < 0 or Vo VDD).....± 20 mA

Maximum output current sunk by any I/O pin..... 25 mA

Maximum output current sourced by any I/O pin ..... 25 mA  
Maximum current sunk or sourced by all pins combined ..... 200 mA

**Disclaimer**

These devices are not intended for use in applications of a critical nature where safety, life, or property is at risk. The user of this product assumes full liability for the use of this product in all applications. Under no conditions will Reynolds Electronics be responsible for losses arising from the use or failure of the device in any application, other than the repair, replacement, or refund limited to the original product purchase price.

Technical support: Email: [tech@rentron.com](mailto:tech@rentron.com)

Sales: [sales@rentron.com](mailto:sales@rentron.com)

Distributor inquiries: [sales@rentron.com](mailto:sales@rentron.com)

Copyright © 2006 Reynolds Electronics

3101 Eastridge Lane

Canon City, CO. 81212

Phone: (719) 269-3469

Fax: (719) 276-2853

Web Site: <http://www.rentron.com>

The CIP-8 encoder/decoder IC's are available for purchase online at: <http://www.rentron.com>

1 2 3 4

A

B

C

D

1 2 3 4

D

C

B

A Title

Size Number Revision

Orcad A

Date: 7-Nov-2006 Sheet of

File: C:\CAD\SCHEMATICS.Ddb Drawn By:

D4

D5

D6

D7

VCC

A7

A6

A5

A1 A0 / BAUD

A2

A3

A4

GND

D0

D1 D2

D3

CIP-8D

0.1uF

L / M

D5

D4

D3

D2

D0

D1

(SILVER DOT) DECODER

NOTE: ALL ADDRESS PINS MUST BE AT GROUND OR VCC

LED

430

2.2K NPN

10K

1N4148

RELAY

EXAMPLE RELAY DRIVE CIRCUIT

LOAD

DIN

25 mA MAX PER OUTPUT PIN | SINK OR SOURCE | 200 mA MAX (ALL COMBINED)

DO NOT ALLOW TO FLOAT

GROUNDING /TE PIN INITIATES DATA TRANSMISSION

FOR 8-BIT "CIP-8E" ENCODER & "CIP-8D" DECODER IC's

EXAMPLE DIRECT LED DRIVE

8 x HIGH-CURRENT OUTPUTS

LATCH MODE

DATA IN FROM RECEIVER DATA OUTPUT

## CIP-8E / CIP-8D 8-BIT ENCODER / DECODER EXAMPLES

THE SINGLE IC SOLUTION FOR BOTH REMOTE CONTROL TRANSMITTER AND RECEIVER

8-BITS ADDRESS / DATA WITH UP TO 25mA PER DECODER OUTPUT

USE 100K TO 200K EXTERNAL PULL-UP AS SHOWN ABOVE

Copyright (C) 2007 Reynolds Electronics

3101 Eastridge Lane



Canon City, CO. 81212  
Website: <http://www.rentron.com> 1 of 1  
B. REYNOLDS  
CIP-8E / CIP-8D A.1  
SAMPLE ENCODER / DECODER CIRCUIT SCHEMATICS  
D7  
D6  
DIN  
D4  
D5  
D6  
D7  
VCC  
A7  
A6  
A5  
A1 A0 / BAUD  
A2  
A3  
A4  
GND  
D0  
D1 D2  
D3  
CIP-8E  
0.1uF  
/ TE  
(GOLD DOT) ENCODER  
DOUT  
VCC  
VCC  
VCC  
VCC  
VCC  
DOUT TO RF TRANSMITTER  
SPDT TOGGLE SWITCHES  
FOR ENCODER DATA INPUTS  
4800 bps  
2400 bps  
2400 bps  
4800 bps  
ADDRESS PINS MAY BE CONNECTED TO GROUND, VCC, OR ANY COMBINATION  
OF GROUND & VCC, AND SHOULD NOT BE ALLOWED TO FLOAT  
200K PULL-UP  
VCC  
VCC  
WITH < 20mV P-P NOISE / HASH FOR BEST RESULTS  
DECODER ABSOLUTE MAX DRIVE CURRENT:  
VCC = +3.0V TO +5.5V DC  
VCC  
MOMENTARY MODE  
TRANSMIT ENABLE  
1  
10 11  
20  
1 20  
10 11

# APPENDIX D



Order this document by TCA3388/D

## TCA3388

### Advance Information Telephone Line Interface

The TCA3388 is a telephone line interface circuit which performs the basic functions of a telephone set in combination with a microcontroller and a ringer. It includes dc and ac line termination, the hybrid function with 2 adjustable sidetone networks, handset connections and an efficient supply point.

#### TELEPHONE LINE INTERFACE

SEMICONDUCTOR  
TECHNICAL DATA

#### FEATURES

##### Line Driver and Supply

- DC and AC Termination of the Telephone Line
- Selectable DC Mask: France, U.K., Low Voltage
- Current Protection
- Adjustable Set Impedance for Resistive and Complex Termination
- Efficient Supply Point for Peripherals
- Hook Status Detection

##### Handset Operation

- Transmit and Receive Amplifiers
- Double Anti-Sidetone Network
- Line Length AGC
- Microphone and Earpiece Mute
- Transmit Amplifier Soft Clipping

##### Dialing and Ringing

- Interrupter Driver for Pulse-Dialing
- Reduced Current Consumption During Pulse-Dialing
- DTMF Interfacing
- Ringing via External Ringer

##### Application Areas

- Corded Telephony
- Cordless Telephony Base Station
- Answering Machines
- Fax
- Intercom
- Modem

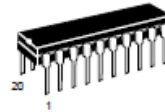

DP SUFFIX  
PLASTIC PACKAGE  
CASE 738



FP SUFFIX  
PLASTIC PACKAGE  
CASE 751D

#### PIN CONNECTIONS

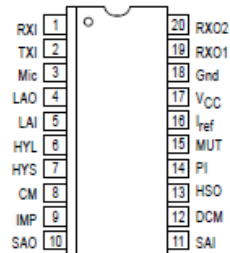

(Top View)

#### ORDERING INFORMATION

Device	Tested Operating Temperature Range	Package
TCA3388DP	$T_A = 0^\circ$ to $+70^\circ\text{C}$	DIP
TCA3388FP		SOIC

This document contains information on a new product. Specifications and information herein are subject to change without notice.

© Motorola, Inc. 1995